



VIKAS INDUSTRIES

A GOVT. OF INDIA RECOGNISED STAR EXPORT HOUSE



AN ISO 9001: 2015 CERTIFIED COMPANY
A UL LISTED COMPANY

FULL COUPLING

ASME B16.11-2016 (Revision of ASME B16.11-2011)

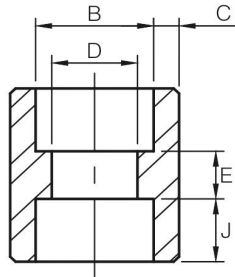

Dimensions are in millimeters.

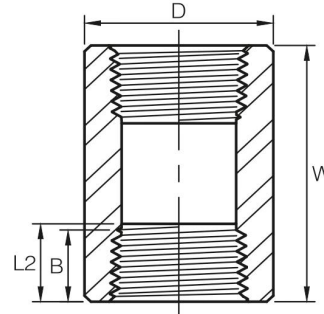

Dimensions are in millimeters.

DN	Nom. Pipe Size	B ⁽²⁾	C ⁽¹⁾		D ⁽²⁾	E ⁽²⁾	J (Min)
			(Avg)	(Min)			

3000Lb

6	1/8	10.8	3.18	3.18	6.9	6.5	9.5
8	1/4	14.2	3.78	3.30	9.3	6.5	9.5
10	3/8	17.6	4.01	3.50	12.6	6.5	9.5
15	1/2	21.8	4.67	4.09	15.8	9.5	9.5
20	3/4	27.2	4.90	4.27	21.0	9.5	12.5
25	1	33.9	5.69	4.98	26.7	12.5	12.5
32	1-1/4	42.7	6.07	5.28	35.1	12.5	12.5
40	1-1/2	48.8	6.35	5.54	40.9	12.5	12.5
50	2	61.2	6.93	6.04	52.5	19.0	16.0
65	2-1/2	73.9	8.76	7.67	62.7	19.0	16.0
80	3	89.8	9.52	8.30	78.0	19.0	16.0
100	4	115.2	10.69	9.35	102.3	19.0	19.0

6000Lb

6	1/8	10.8	3.96	3.43	4.0	6.5	9.5
8	1/4	14.2	4.60	4.01	6.4	6.5	9.5
10	3/8	17.6	5.03	4.37	9.2	6.5	9.5
15	1/2	21.8	5.97	5.18	11.8	9.5	9.5
20	3/4	27.2	6.96	6.04	15.6	9.5	12.5
25	1	33.9	7.92	6.93	20.7	12.5	12.5
32	1-1/4	42.7	7.92	6.93	29.5	12.5	12.5
40	1-1/2	48.8	8.92	7.80	34.0	12.5	12.5
50	2	61.2	10.92	9.50	42.9	19.0	16.0

9000Lb

15	1/2	21.8	9.35	8.18	6.4	9.5	9.5
20	3/4	27.2	9.78	8.56	11.1	9.5	12.5
25	1	33.9	11.38	9.96	15.2	12.5	12.5
32	1-1/4	42.7	12.14	10.62	22.8	12.5	12.5
40	1-1/2	48.8	12.70	11.12	28.0	12.5	12.5
50	2	61.2	13.84	12.12	38.2	19.0	16.0

(1) Average of socket wall thickness around periphery shall be no less than listed values. The minimum values are permitted in localize areas.

(2) Tolerance see page 14

(3) Reducer : "C, J, E" in accordance with large size.

"D" in accordance with small size.

The others in accordance with each size.

DN	Nom. Pipe Size	Length of Thread (Min)		W	D
		B ^(*)	L ^(*)		

3000Lb

6	1/8	6.4	6.7	32	16
8	1/4	8.1	10.2	35	19
10	3/8	9.1	10.4	38	22
15	1/2	10.9	13.6	48	28
20	3/4	12.7	13.9	51	35
25	1	14.7	17.3	60	44
32	1-1/4	17.0	18.0	67	57
40	1-1/2	17.8	18.4	79	64
50	2	19.0	19.2	86	76
65	2-1/2	23.6	28.9	92	92
80	3	25.9	30.5	108	108
100	4	27.7	33.0	121	140

6000Lb

6	1/8	6.4	6.7	32	22
8	1/4	8.1	10.2	35	25
10	3/8	9.1	10.4	38	32
15	1/2	10.9	13.6	48	38
20	3/4	12.7	13.9	51	44
25	1	14.7	17.3	60	57
32	1-1/4	17.0	18.0	67	64
40	1-1/2	17.8	18.4	79	76
50	2	19.0	19.2	86	92
65	2-1/2	23.6	28.9	92	108
80	3	25.9	30.5	108	127
100	4	27.7	33.0	121	159

(*) Dimension B is minimum length of perfect thread. The length of useful thread (B plus threads with fully formed roots and flat crests) shall not be less than L2 (effective length of external thread) required by American National Standard for pipe threads (ANSI / ASME B1.20.1)

F-76-77, Phase-VII, Focal Point, Ludhiana-141010 (Pb.) INDIA

Works : Focal Point Extn., Dhandari Khurd, Ludhiana.

Mobile: +91-98140-03794, +91-98554-29173, +91-98554-29174

E-mail: export@vikasindustriesindia.com, info@vikasindustriesindia.com

www.vikasindustries.net